

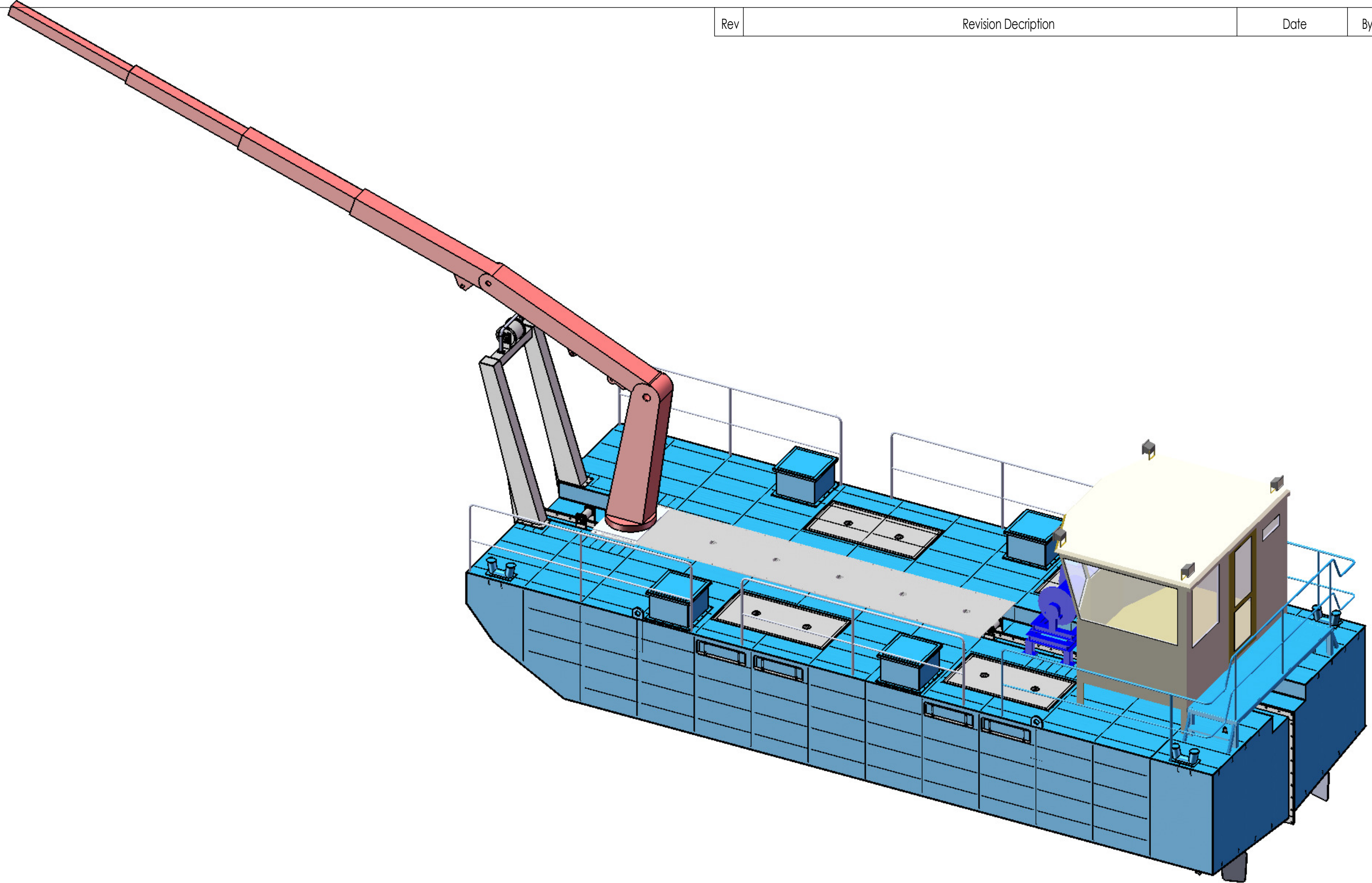

Rev	Revision Description	Date	By	Appr
-----	----------------------	------	----	------



This document must not be copied without our written permission, and the contents thereof must not be imparted to a third party not be used for any unauthorized purpose, convention will be prosecuted. This drawing is made to size A3, if the paper size is different the scale is not right.

 Verkstad Planering Ab Suunnittelu Oy Tel: +358-2-4582 500 Fax: +358-2-4582 011 Konepaja	Mass	Page/Pages 1/2		Scale 1:50	Design	TSV	060907
	Customer Workboat	Divided hull workboat GA		Code 125W07	Check		
				Appr			Rev D

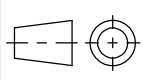
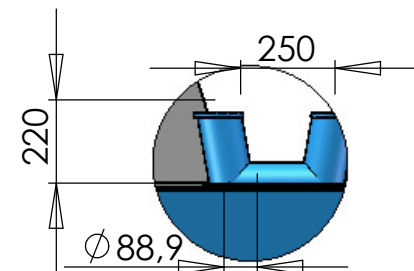
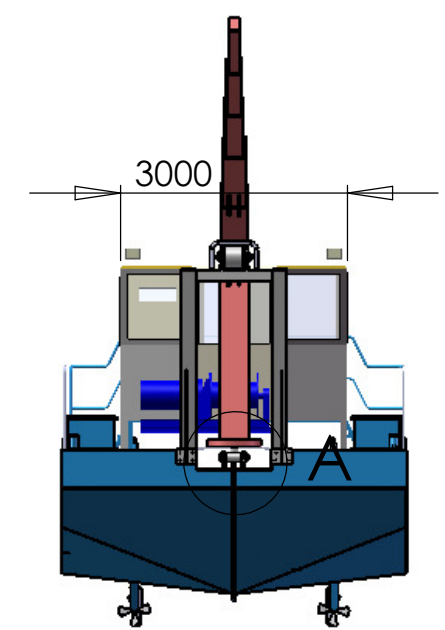
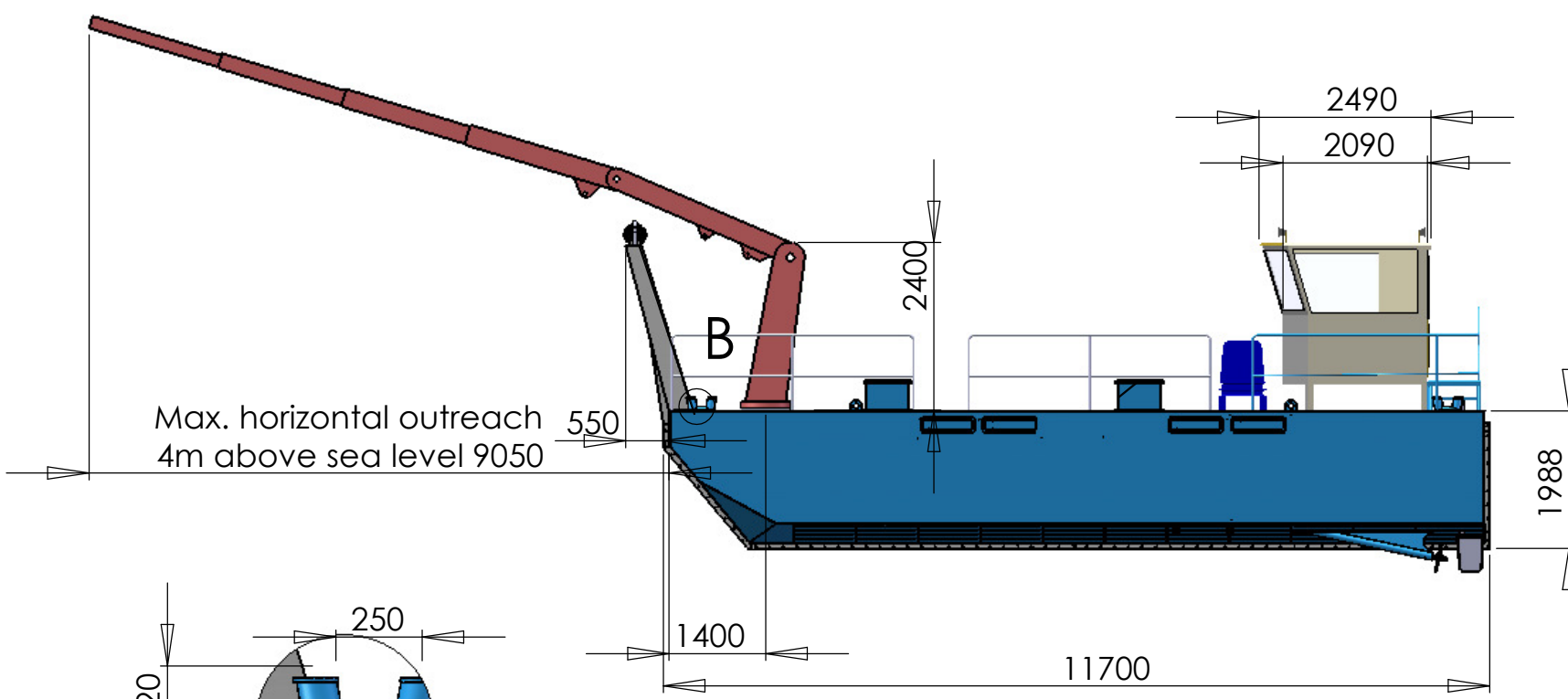

DETAIL B
SCALE 1 : 20

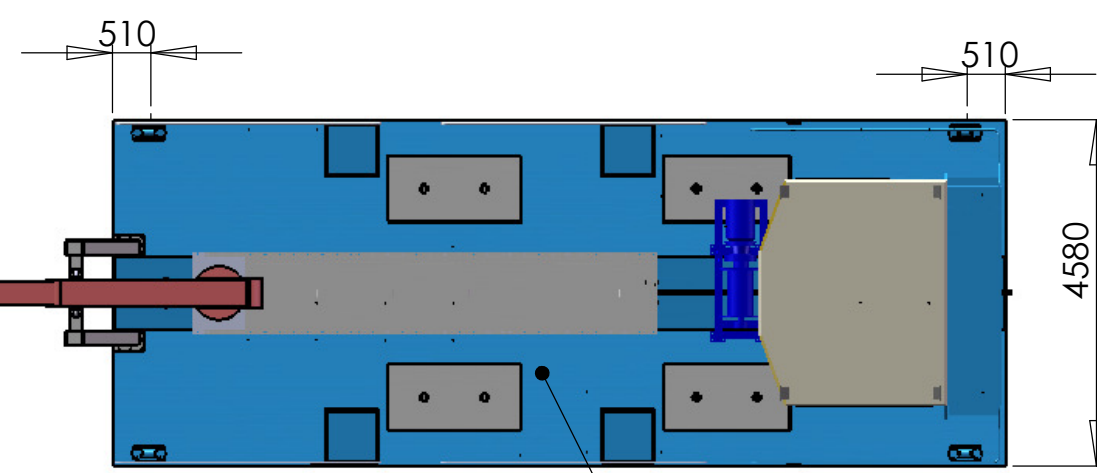

Reinforced load area

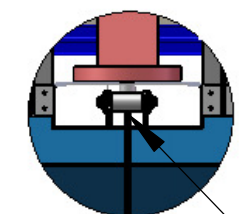

DETAIL A
SCALE 1 : 50

LOA 11,7m
B 4,58m
Height with propellers 5.5m
Hull is in 2 pieces 2.29mx1 1,7m
2x perkins Sabre M130C

Hull pieces bolted together

Note: all dimensions in millimeters
All weldings according to EN ISO 287-1
Welding process: Electrode welding 111, MIG131, MIG137, TIG141

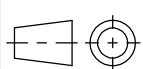
 Konepaja Verktad Planering Ab Suunnittelu Oy Tel: +358-2-4582 500 Fax: +358-2-4582 011	Mass	Page/Pages 2/2	 Scale 1:100	Design	TSV	060907
	Customer Workboat	Divided hull workboat GA		Code 125W07	Check	
				Appr		Rev D

This document must not be copied without our written permission, and the contents thereof must not be imparted to a third party nor be used for any unauthorized purpose, convention will be prosecuted. This drawing is made to size A3, if the paper size is different the scale is not right.